

# Loading & Unloading Skid

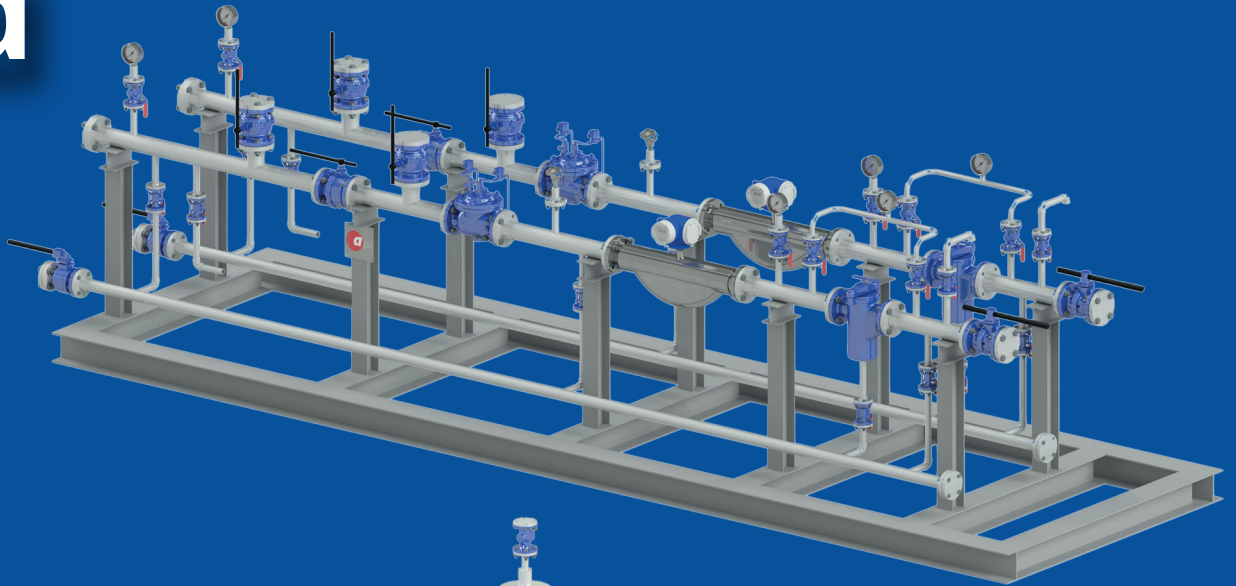

• Sensing • Measuring • Controlling • Automation

**UK | USA | UAE | INDIA | ITALY | IRAQ | KSA | OMAN | TURKEY**

[www.autocontrolpi.com](http://www.autocontrolpi.com)



## About Us



Autocontrol Process Instrumentation (API) Originates from Autocontrol Technologies, a Company established in 1994 Italy.

Autocontrol Process Instrumentation (API) provide the complete Design, Engineering, Integration, fabrication, Technical support, Test, Commissioning and handover for all package system for Oil & Gas, Petrochemical, Chemical and Power industries as per the customer requirement. We also focused on Sensing Technologies, Measuring Instruments, Controlling Equipment, Automation Systems and all related Accessories. While API's activities cover a wider range of products, services and packages.

API's products are approved by International and National Oil and Gas Operators, Energy, Utilities and Industrial Companies.

We study and research on your requested systems and utilize best and competitive Technologies and instruments to meet your requirements.

For more information, please ask for a copy of our integrated company profile, or visit:

[www.autocontrolpi.com](http://www.autocontrolpi.com)

Whatever you need, we can sense it...  
Measure it... Control it and if necessary...  
automate it....



## Loading & Unloading Skid

### Loading Skid:

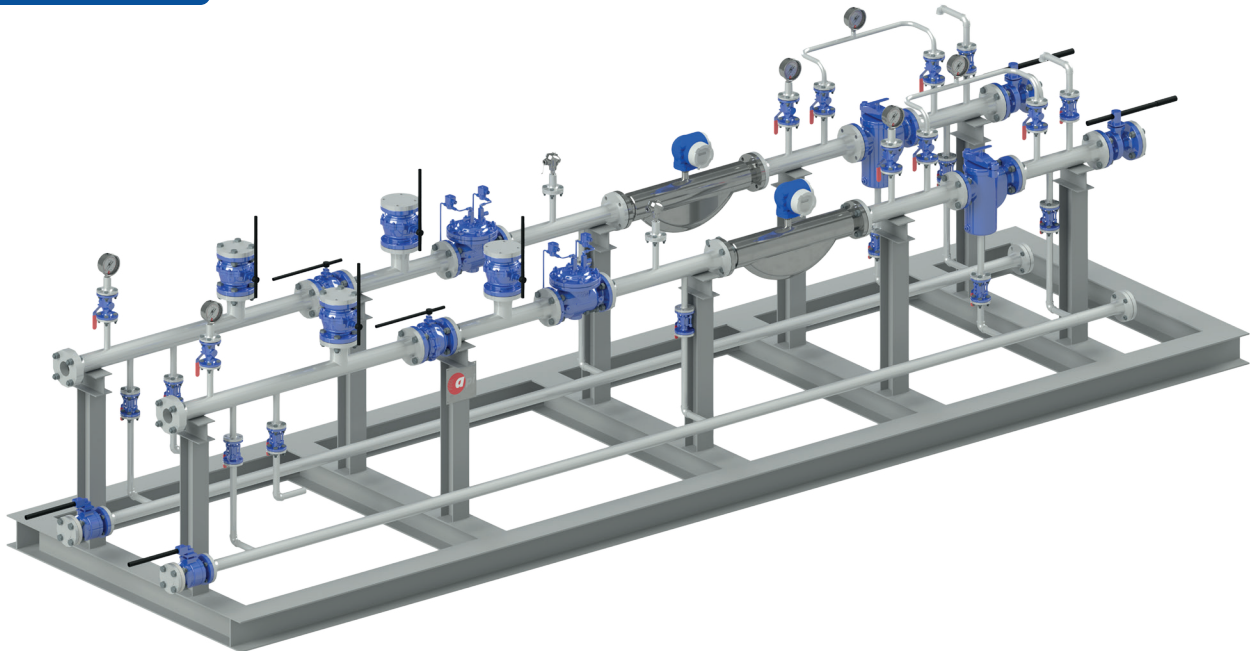

Autocontrol Process Instrumentation (API) is a leading global supplier of tanker truck Loading skid systems. API provides packaged solutions for tanker truck loading for all petroleum, hydrocarbons, chemicals, and other fluids.

Our tanker truck loading skids are engineered with safety and accuracy in mind and will meet all OSHA, government and industry standards such as API, AWS, ASME, NEC, and UL.

We also offer our clients fully designed truck-unloading skid systems and terminal controls, as well as offer installation and on-site start up commissioning assistance. All of our systems are fully tested at our manufacturing facility and must pass Autocontrol process Instrumentation (API) QA standards and certification before shipment to client.

#### Truck Loading-Offloading Skid Applications:

- LPG (Liquefied Petroleum Gas)
- Sulfuric Acid
- Crude Oil
- LNG (Liquefied Natural Gas)
- Diesel
- Aviation and Jet Fuels
- High-Concentrate Hydrogen Peroxide

#### Truck Loading-Offloading Skids Industry Standards:

- Pipe fabrication to ASME Section IX standards
- Structural steel designed to AWS standards
- Pressure Vessel Fabrication to Section VIII Standards

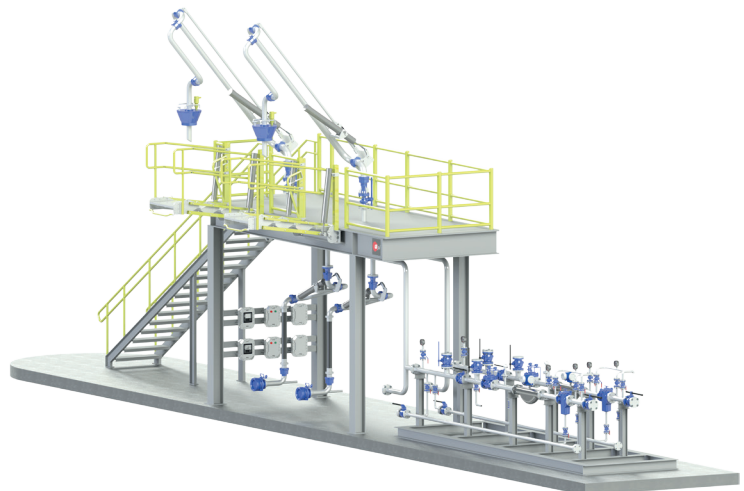

## Loading & Unloading Skid

### Unloading Skid:



With the need to transfer bulk product from tanker truck to a storage tank and transferring the product to intermediate tank, requirement of safe unloading package & pumping package arises.

To ensure the reliable and safe tanker truck unloading and pumping for Oil & Gas and Power Generation companies, Woodfield provides its Unloading and Pump Skid solutions using centrifugal pump meeting API 608 standard's requirements.

These pump skid solutions are custom made unloading, pumping packages and are designed based on end user's unloading capacity requirement, process condition, configuration, service, type of pumps etc.

Autocontrol Process Instrumentation (API) Unloading pump skids consists of mainly Pumps with motor, strainers, unloading arm/hose, flow meter, re-circulation line valve, relief valves and other associated valves, piping, electrical and structural steel material.

We offer the pump motor, meeting client end user local statutory requirement for hazardous areas certifications like IEC / Atex / NEMA

# Loading & Unloading Skid

## P&ID - Loading Skid:

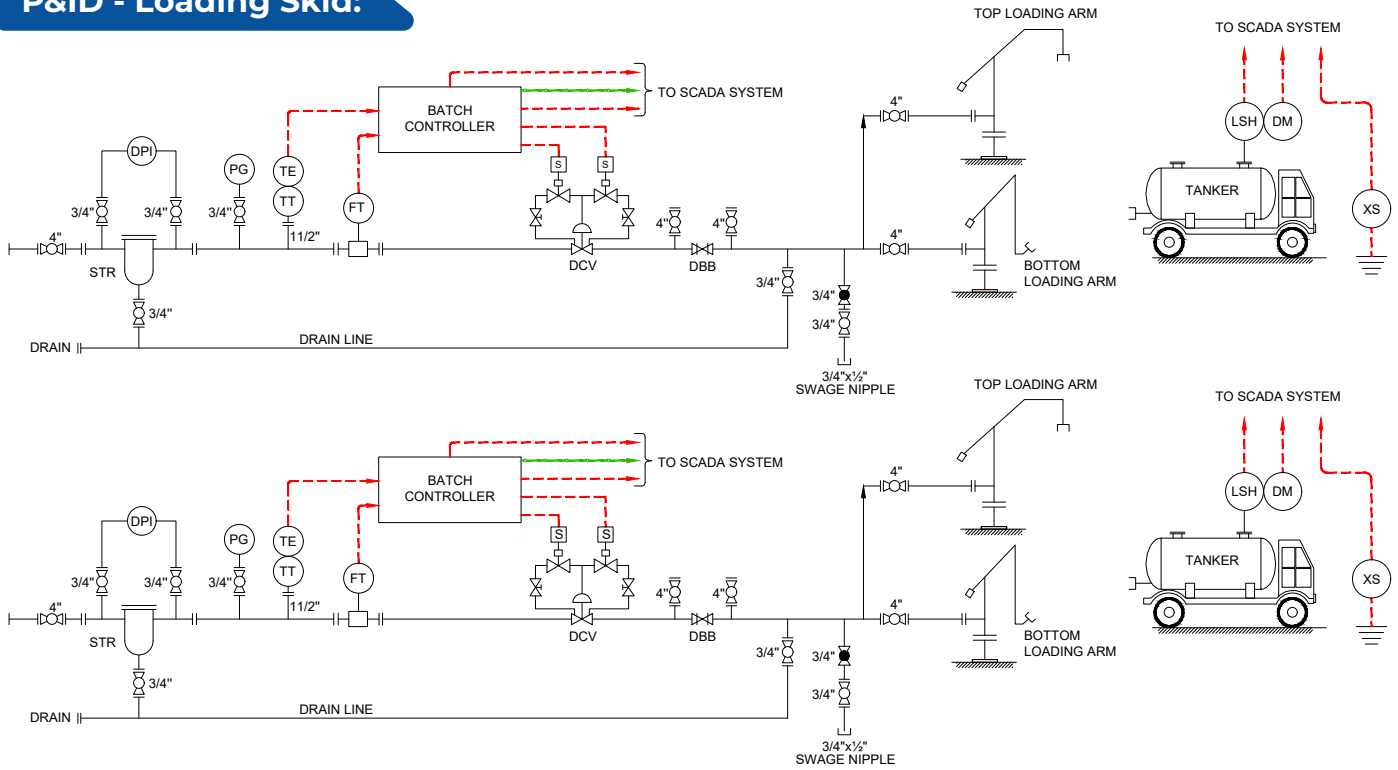

## P&ID - Unloading Skid:

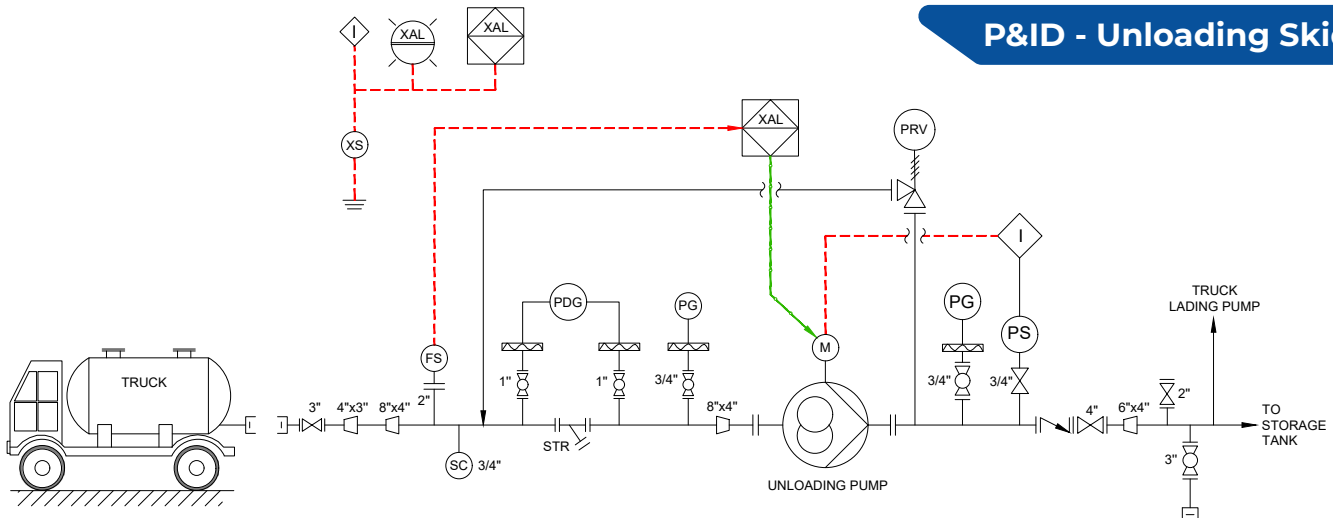

: DIFF. PRESSURE GAUGE	: BALL VALVE	: UNLOADING PUMP	: SOLENOID VALVE	: PRESSURE GAUGE
: STRAINER	: COUPLING	: PRESSURE RELIEF VALVE	: DIGITAL CONTROL VALVE	: TEMP. ELEMENT
: MOTOR	: GATE VALVE	: REDUCER	: DIGITAL CONTROL VALVE	: TEMP. TRANSMITTER
: DIAPHRAGM	: FLOW SWITCH	: CHECK VALVE	: DOUBLE BLOCK & BLEED VALVE	: FLOW TRANSMITTER



# Loading & Unloading Skid

## System Architecture:

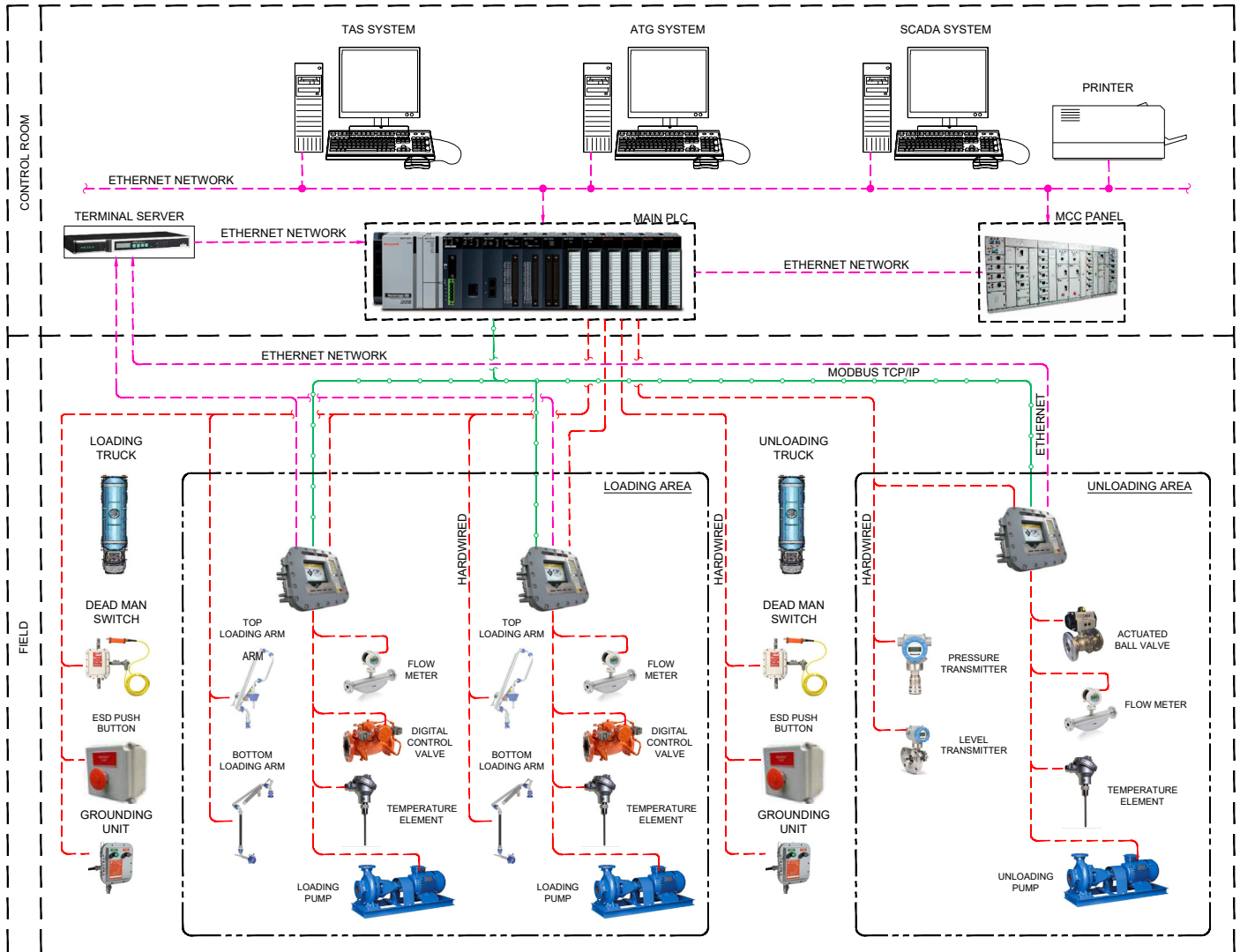

## Installation, Commissioning & Service

### Installation & Commissioning:

Many of our clients have engaged us in the installation and commissioning of the equipment we supply and can therefore be fully confident in site system performance, safety and reliability as was engineered.

### Benefits:

- Turn-key, fully seamless integrated solution, one stop shop with added advantages of foresight.
- Single point of contact and accountability
- Installation and commissioning by engineers experienced and cognizant with the platform and design and who can deliver Innovative Solutions to unexpected site issues as are often encountered.
- Bespoke arrangements
- Immediate and full access to the project engineering team responsible for the application design to advise in any unforeseen site Implementation problems at no additional cost.

### Key Business Benefits Derived:

- Confidence in effective and competent installation and commissioning with easy access to engineering base support
- Contributes to lifetime performance, functional efficacy and safety.
- Cost effective, simplifies management overhead with reduced contractual risk.
- Ensures against third party systematic errors with immediate and/or potential later incurred costs.

### Our Service offering:

The system you have purchased has been engineered, manufactured and tested to the highest standard. However, we recognize that The system will serve its purpose to the maximum efficacy where competent engineering is engaged throughout its entire life cycle and not just up to point of delivery and later application of highly competent operations and maintenance. An engineering solution that is well designed, built and tested can easily be compromised by insufficiently enlightened installation or Commissioning that can act in detriment to the longer term system performance, safety, reliability and application. It is more often So, as an imperative, that installation and commissioning requires extensive knowledge of the platform, application and site Integration.

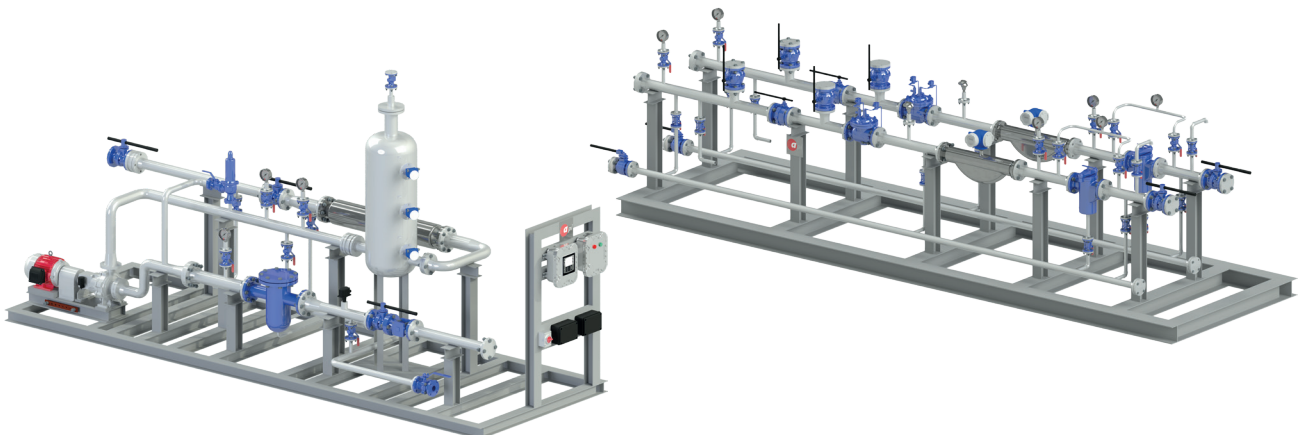

## Our Global Presence

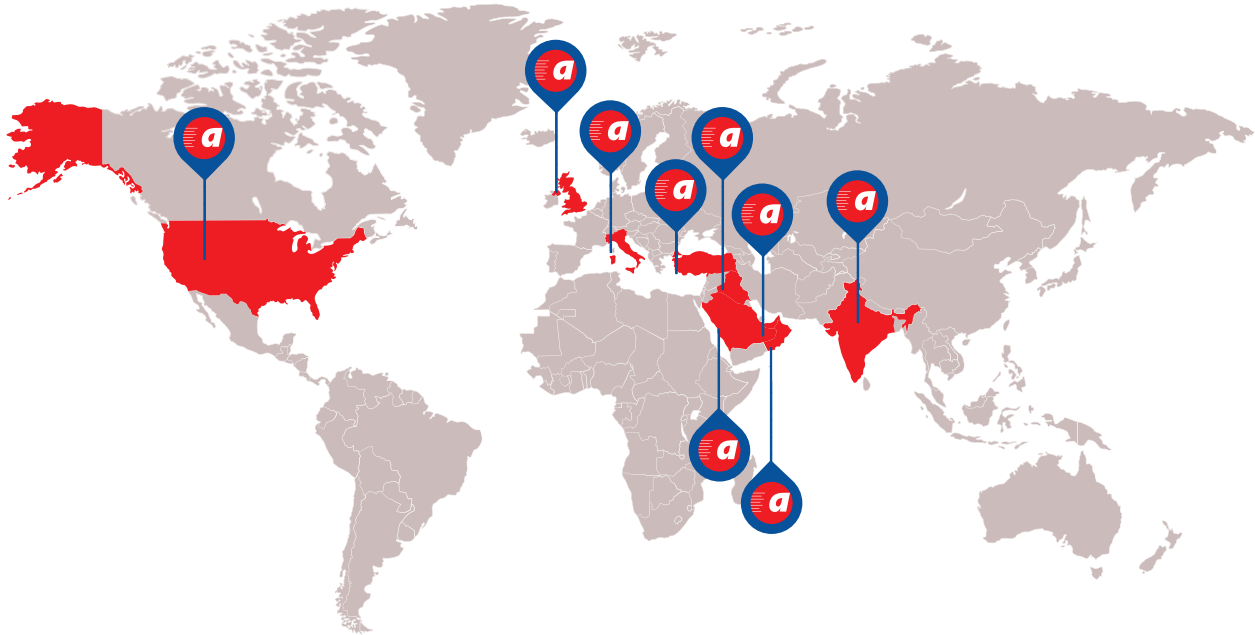

### UK

Autocontrol Process Instrumentation Ltd.

Unit B4; Greeba Road; Southmoor Industrial Park Wythenshawe; Greater Manchester, England Post Code - M23 9XS, United Kingdom

+44 161 5074 443

sales.uk@autocontrolpi.com

www.autocontrolpi.com

### USA

Autocontrol Americas Inc.

Unit 24/26 220 Barren Springs Dr, Houston, Texas 77090, United States of America

sales.usa@autocontrolamericas.com

www.autocontrolamericas.com

### UAE

Autocontrol Process Instrumentation FZC.

Plot No. 1H-08B, PO Box 51722, Hamriya Free Zone , Phase 1, Sharjah, United Arab Emirates.

sales.uae@autocontrolpi.com

www.autocontrolpi.com

### INDIA

Autocontrol Process Instrumentation Pvt. Ltd.

Plot No-B-85/4, Ambernath Additional MIDC, Anand Nagar, Nr. ASB Company, Ambernath, Thane, Maharastra, India - 421506

sales.india@autocontrolpi.com

www.autocontrolpi.com

### ITALY

Autocontrol Europe Srl.

Via Vittorio Veneto, 23, Cap 20010 Bernate Ticino Milano, Italy

sales.europe@autocontroleurope.com

www.autocontroleurope.com

### IRAQ

Autocontrol Process Instrumentation FZE.

Italian City1, Villa 59 Erbil Kurdistan, Iraq

sales.iraq@autocontrolpi.com

www.autocontrolpi.com

### KSA

Autocontrol Process Instrumentation LLC.

Unit S1/2/44, Dammam 2nd Industrial Area, West (SCOOP) Kingdom of Saudi Arabia

sales.ksa@autocontrolpi.com

www.autocontrolpi.com

### OMAN

Autocontrol Process Instrumentation LLC.

Ghala Al Sanaiah, Bousher, Postal Code 112, Muscat Governorate, Muscat, Oman

sales.oman@autocontrolpi.com

www.autocontrolpi.com

### TURKEY

Autocontrol Process Instrumentation Elektronik Imalat Ticaret Sanayi Limited Sirketi

Ornek, Bestekar Amir Ates Cd. No. 10A, 34704 Atasehir, Istanbul, Turkey

sales.turkey@autocontrolpi.com

www.autocontrolpi.com



# Notes

A large area for taking notes, consisting of horizontal dashed lines.



• Sensing • Measuring • Controlling • Automation

**UK | USA | UAE | INDIA | ITALY | IRAQ | KSA | OMAN | TURKEY**

[www.autocontrolpi.com](http://www.autocontrolpi.com)